

RelayGo

TIPS AND TRICKS

FEBRUARY #15 HOT TOPIC: WHY GOLD CONTACTS MATTER?

Did you know that our RQ41 standard relays has gold flashed contacts?



Gold flashed contacts (0.2, 0.3 μ Au) assure the best switching with low loads and preserve the contacts of oxidation, for example, when the relay is storage. The purpose of the protection is to extend the expected life of the contacts and its reliability under unfavorable weather conditions.

We are the only manufacture that is able to offer under request Gold Plated (2, 3 and 10 μ Au) contacts our entire standard relays series.

RelayGo also offers the possibility to use Gold Plated Twin Contacts in all RM, RQ and RF series.



Twin contacts increase the assurance of low loads switching from 1mA@5V up to 5A. We always recommend use Twin Contacts to guaranty the correct reliability of the contacts for electronic controls than need low loads currents. This feature guarantees the decrease of the MTBF (Mean Time Between Failures) up to levels of full reliability

If your application needs a current higher than \approx 2A, we recommend our clients to chose a different type of relay.

RelayGo

TIPS AND TRICKS









MARCH #15 HOT TOPIC: KEEP CALM AND USE REMANENCE RELAYS

As you may know most relays are monostable, but remanence relays has the ability to return to the idle state when the excitation is switched from the terminal off because they are bistable relays. High remanence magnetic circuit allows the relay to latch when the current applied flows through the coil in a direction and unlatches if the current flows in the opposite direction. Electronic circuitry is added inside the relay, with diodes and precise resistances to control and protect against transitory pulses. The current switching state is retained irrespective of the excitation, which it is really useful for monitoring and control circuits.

The best advantage of using remanence relays is its ability to memorize the position where the relay was operating for the last time. That's why some of the most common applications for remanence relays are surveillance and control, security, process monitoring without electronic memories and monitoring of electrical installations for example.

A remanence relay makes your installation safe and easy.

OUR REMANENCE RELAYS ARE:

	RM2019 2 CHANGE-OVER CONTACTS, REMANENCE, 11 PINS, DPDT		Magnetic remanence 10 A 250 V AC-1 0,5 A 110 V DC-1 10 A 30 V DC-1 0,2 A 220 V DC-1
	RM3019 3 CHANGE-OVER CONTACTS, REMANENCE, 12 FASTON, TPDT		Magnetic remanence 10 A 250 V AC-1 0,5 A 110 V DC-1 10 A 30 V DC-1 0,2 A 220 V DC-1
	RP2019 2 CHANGE-OVER CONTACTS, REMANENCE, 9 FASTON, DPDT		Magnetic remanence 10 A 400 V AC1 10 A 30 V DC1 0,2 A 250 V Ind 0,5 A 110 V DC1
	RQ2119 2 CHANGE-OVER CONTACTS, REMANENCE, 9 FASTON DPDT		Magnetic remanence 5 A 1200 V AC-1 5 A 30V DC-1 0,2 A 110 V DC-1



RELAYGO'S FAMILIES ARE GROWING



NEW
MULTI VOLTAGE RELAY
FOR **ALL** OUR FAMILIES.

WORKS FROM
24V TO 240V
AC/DC

RelayGo

TIPS AND TRICKS

MAY #15 HOT TOPIC: TWIN CONTACTS. DIVIDE AND RULE

Would you able to differentiate a twin contact at first glance?

It's easy to appreciate how in a twin or bifurcated contact, all their blades are divided into two parts, each one with their own contact. Each of this twin contacts press simultaneously on the independent fixed connections of the relay. And this coordinated effort is most useful when you want to switch low loads with very high reliability.

When should you use a twin contact?

Four of our families (RM, RQ, RF and RR) offer the possibility of including twin contacts, and they are considered the most suitable at the time of switching very low signals -from 1mA @ 5V to 5A-; because they achieved a mean time between failures (MTBF) that optimizes the switching reliability.

All of these features shape the suitable relay in cases where the installations have such a small signal (below 50 mA) that make a common relay does not work properly. For example, an interface relay for a frequency inverter or an input signal to a PLC.

OUR TWIN CONTACTS RELAY ARE:



RM2117
2 TWIN CHANGE-OVER CONTACTS, 8 PINS, DPDT



Low signal application
6 A 250 V AC-1
6 A 30 V DC-1
5 mA / 5V
1mA/5V DC-1



RM3117
3 TWIN CONTACTS, 11 PINS, TPDT



Low signal, three change-over
6 A 250 V AC-1 6 A 30 V DC-1
5mA/5 V 1mA/5 V DC-1



RQ2117
2 TWIN CONTACTS, 8 FASTON, DPDT



Low signal
6 A 250 V AC-1 6 A 30 VDC-1
5 mA / 5 V 1 mA / 5 VDC-1



RF1217

1 TWIN CHANGE-OVER CONTACT, 5 FASTON, SPDT



Low signal
6 A 250 V AC-1 0,5 A 110 V DC-1
6 A 30 V DC-1 0,2 A 220 V DC-1



RF1222

1 TWIN CHANGE-OVER CONTACT, (NO), 4 FASTON, SPST

Application for VDC
6 A 250 V AC-1 0,8 A 110 V DC-1
6 A 30 V DC-1 0,6 A 220 V DC-1



RR2117

2 CHANGE-OVER BIFURCATED CONTACTS, 8 FASTON, DPDT



Application for railway
6 A 250 V AC-1 6 A 30 V DC-1



TIPS AND TRICKS

JUNE #15 HOT TOPIC: DID YOU KNOW SOME RELAYS HAVE SUPERPOWERS?

The distance between contacts (known as gap) and its speed of opening, significantly influence the length and duration of the arc electric, which is responsible for the relays premature deterioration. When we switch DC loads, a GAP 0.5 mm. should be enough to arc extinction in most cases. However, when we are switching loads that exceed 10 amps or DC high loads; the erosion of contacts, the arc electric, and the loss of insulation between the contacts cause serious damages in the contacts and limit the life and reliability of the relays.

RELAYGO OFFERS SEVERAL OPTIONS TO SOLVE THESE PROBLEMS:

First, we could use different material alloys in the contacts, such as AgSnO₂, which reduces erosion of contacts.

Also, we could also increase the distance between contacts (GAP) using or combining:

- Contacts in Series: Two or three contacts in series are equivalent to multiply the GAP increasing VDC cut.
- Contacts in Parallel: Cannot switch higher loads but increases current stability and reliability.
- Twin Contacts: The blade is divided into two parts, each with its own contact, both contacts press down each on their own independent fixed contacts. This system is particularly good for reliably switching at very low levels (increasing MTBF).

- Double Make: The double break contact arrangement is equivalent to two contacts connected in series. The maximum intensity supported corresponds to only one contact. This system allows for higher DC operating voltages. We can strengthen Double Make contacts with a Magnetic Blow Out to lengthen the arc, thus increasing your route and consequently causing uses extinction.

Furthermore, RelayGo offers the possibility of using materials with unusual resistance, enduring larger temperature to 1000 degrees, such as Tungsten. These relays known as overload relays are made by a leading silver contact the steady stream, while another tungsten is responsible for connecting and disconnecting the load. This melting point greater help to resist high power spikes and protect the main contacts of the relay.

SOME EXAMPLES OF OUR PRODUCTS:

RelayGo

TIPS AND TRICKS

JULY #15 HOT TOPIC: WHY SHOULD BE THE RELAYS SENSITIVE SOMETIMES?

The sensitive relays are those which have a power coil significantly lower than the standard ones.

From RelayGo we decided to develop a range of special relays with a low coil power (250-500-800 mW) could keep active a relay and also reduce consumption. These are called sensitive or low signal relays.

THE REASONS FOR CREATING THIS TYPE OF RELAY ARE TWO:

The main reason is that today there are many applications where relays are controlled by electronic systems. This system has certain limitations in the current that they supply and often is not enough to activate a standard relay.

In addition a second reason could be that nowadays it's imperative to use components and products that are energy efficient, for reasons of environmental sustainability and also to reduce costs.

Take out your sensitive side and reduced by 90% your energy consumption.

The smaller is the resistance of an electromechanical circuit, the less energy loss; and therefore greater energy efficiency we achieve.

Our families RM and RQ relays have the option of incorporating sensitive coils and contacts that have minimal contact resistance and high conductivity. This is perfect choice when we want a minimum consumption for very low power that would not activate a standard relay; managing to reduce consumption by nearly 90%.

We recommend using these relays with electronic equipment that require low signals.

OUR SENSITIVE RELAYS ARE:



RM1111
(250mW, 1CO, 11p)



RM2112
(500mW, 2CO, 11p)



RM3113
(800 mW)



RQ2112
Small size
(500 mW)

RelayGo

TIPS AND TRICKS

AUGUST #15 HOT TOPIC: CONVERT YOUR RELAY IN A TIMER

RelayGo's, the Time Cube, connects any brand of 8 and 11-pin relay and socket, transforming standard relays into timer relays. As our Time Cubes are compatible with our RM2 and RM3 series is it possible to commute until 10 amps per each contact, that means that with an RM3 relay you could commute 10 amps with three different applications.

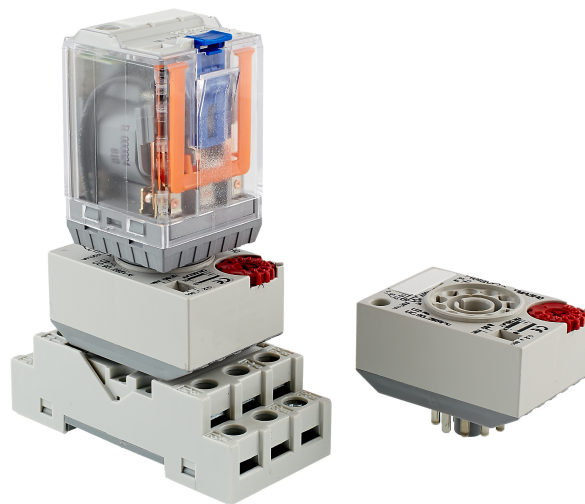

Installation could not be easier: remove the relay, insert the time cube in the socket and replace the relay. The Time Cube adds only 25 mm to the overall height of the relay. One of the multiple advantages to use our Time Cube is that you don't have to replace the whole set, to replace the relay. This solution is offering you a long-term savings besides other product in the market.



TIPS AND TRICKS

OCTOBER #15 HOT TOPIC: WHAT ABOUT THE COIL?

RelayGo is one of the only ones globally manufactures that is able to produce every specific voltage coil to meet our customer needs. YOU DESIGN WE MANUFACTURE

How do we make our Coils?

The coils are molded in polybutylene with fiberglass (130° C). Enamelled wires of Class F specification are used (155° C). They are always verified, 100%, considering quality tolerances. They are wound on automatic precision winding machines, with the number of turns and wire tension accurately regulated and monitored. Coil resistance is measured at 20° C and is regulated within $\pm 10\%$ of specified value.

Also, RelayGo relay's can be manufactured with protection circuits, decreasing or blocking coil generated pulses, as well as block line peaks. Sometimes as a relay is managed by transistors, triacs, etc. it is required to adopt protection measures, peaks might appear in the line, motor switching, electrovalves, transformers, capacitors, etc., on the other hand, as the coil disconnects, inverse voltage peaks appear, and they can create high pulses that are transmitted to other devices connected to the Coil line. Normally a relay is unaffected by these pulses, but if a diode is connected in association with the coil, it must be capable of withstanding an inverse voltage higher than those of the incoming peaks.

- The Freewheeling Diode eliminates the counter electromotive force generated by a coil, in DC, when the relay is disconnected.

- Polarity and FW Diode combination: The polarity diode protects the FW diode of short circuit and possible destruction by reversing the polarity.

- The R VAC circuit (resistor and capacitor) offers the function is to suppress the peaks in AC coils.

Smart Relay Simple Life

All our circuits are inserted inside the relay; you don't have to buy additional components, as external modules to install in the socket. All in One solution.

OUR DIODE OPTIONS ARE:

RM RELAYS

- L** - **Led indicator with rectifier**
VAC y VDC Relay up to 250 V
1000 V up to 24 V
2000 V from 25 to 60 V
4000 V from 61 to 250 V
- D** - **Free Wheeling diode**
Reduce peaks caused by the relay coil on de-energization.
2000 V up to 60 Vdc
4000 V from 61 to 250 Vdc
- E** - **Polarity and free wheeling diodes**
A diode in series with the coil protects the relay from reverse connection.
1000 V up to 60 Vdc
4000 V from 61 to 250 Vdc
- U** - **Bridge rectifier incorporated VDC / VAC**
Available only in voltages up to 60 V.
Protection 1000 V
Previous circuits, E, D, U, can be combined with L, LED incorporated: LE, LD, LU.
- R** - **Resistor and Capacitor**
No Led available.
Only AC coils.

Circuit Scheme

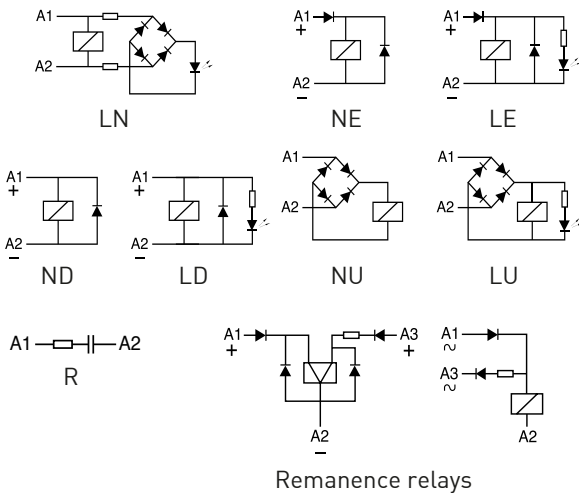

RQ RELAYS

- L** - **Led indicator with rectifier**
VAC y VDC Relay up to 250 V
1000 V up to 24 V
2000 V from 25 to 60 V
4000 V from 61 to 250 V
Note: LED connected in series with the coil @ 220 Vdc in RQ types.
- D** - **Free Wheeling diode**
Reduce peaks caused by the relay coil on de-energization.
2000 V up to 60 Vdc
4000 V from 61 to 250 Vdc
2000 on RQ types
- E** - **Polarity and free wheeling diodes**
A diode in series with the coil protects the relay from reverse connection.
1000 V up to 60 Vdc
4000 V from 61 to 250 Vdc
2000 V on RQ types
- U** - **Bridge rectifier incorporated VDC / VAC**
Available only in voltages up to 60 V.
Protection 1000 V
Previous circuits, E, D, U, can be combined with L, LED incorporated: LE, LD, LU.

RF RELAYS

- L** - **Led no polarity**
Bridge rectifier parallel coil ≤ 12 VDC / VAC
Bridge rectifier serial coil ≥ 12 VDC / VAC
- LE** - **Led A+ polarity (optional)**
All VDC voltages, polarity and freewheel diodes.
- LU** - **Led no polarity only in 24 and 48 VDC (optional)**
Bridge rectifier for VAC/VDC relays.
- R** - **Resistor and Capacitor**
No Led available.
Available for VAC coils VAC pulse RC protection.

